

Liquid Tight Strain Relief – 90° Snap Elbow Fittings PG/Metric Threads – Nickel Plated Brass



PART NUMBERS with Mounting Flange	CABLE RANGE inches (mm)	THREAD TYPE AND SIZE For thread specs see page 29	DIMENSIONS INCHES (MM)				
			A Clearance Hole +.010" +.25 mm 0 0"	H Body Height Fittings	L Body Length Fittings	D Thread Length Fittings	E Wrenching Flat 3C
ED20FA-BR ED20FR-BR	.39 - .55 (10 - 14) .28 - .47 (7 - 12)	Flange	.78 (20)	1.30 (33)	2.60 (66)	NA	.98 (25)



Threaded / Single Hole Connection

PART NUMBERS with Connection Thread	CABLE RANGE inches (mm)	THREAD TYPE AND SIZE For thread specs see page 29	DIMENSIONS INCHES (MM)				
			A Clearance Hole +.010" +.25 mm 0 0"	H Body Height Fittings	L Body Length Fittings	D Thread Length Fittings	E Wrenching Flat 3C
ED20MA-BR ED20MR-BR	.39 - .55 (10 - 14) .28 - .47 (7 - 12)	M20 x 1,5	.79 (20)	1.30 (33)	2.60 (66)	.24 (6)	.98 (25)
ED13AA-BR ED13AR-BR	.39 - .55 (10 - 14) .28 - .47 (7 - 12)	PG 13,5	.80 (20.3)	1.30 (33)	2.60 (66)	.24 (6)	.98 (25)

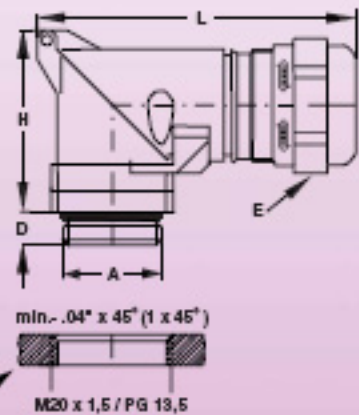

Locking Nuts, see page 22. (Ordered Separately)

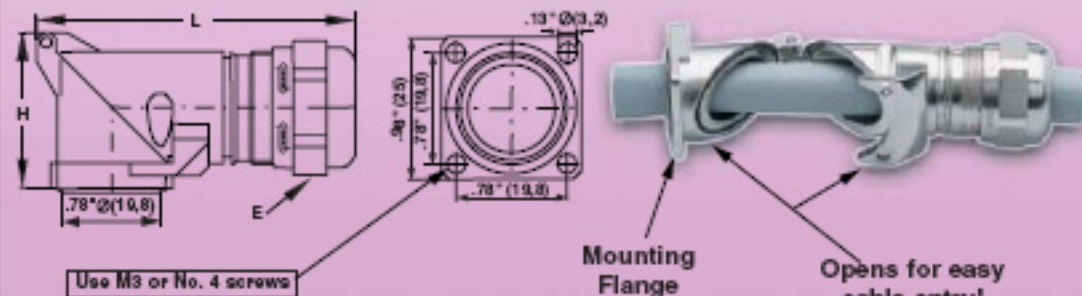

Use M3 or No. 4 screws

Mounting Flange

Opens for easy cable entry!

SPECIFICATIONS:

Pressure rating:
150 PSIG (10 BAR) NEMA 4x and 6
(Submersible) IP68

Materials:

Body & Nut: Nickel Plated Brass
Splined Bushing: Nylon 6/6
Form Seal: Buna-N
O-Ring(Optional): Buna-N

Operating Temperature:

-40°F to 212°F (-40°C to 100°C)

HIGH PERFORMANCE: Strain Relief Fittings with Clamp PG/NPT/Metric Threads – Nickel Plated Brass



PART NUMBERS Clamp Fittings	CABLE RANGE inches (mm)	THREAD TYPE AND SIZE For thread specs see page 29	DIMENSIONS INCHES (MM)			
			A Clearance Hole +.010" +.25 mm 0 0"	B Body Height Clamp Fittings	D Thread Length Fittings	E ₁ /E Wrenching Flats 3C
CD12MA-MZ	.11 - .26 (3 - 6.5)	M12 x 1,5	.49 (12.0)	1.02(26)	.20 (5)	.55 (14)
CD07AA-MZ	.11 - .26 (3 - 6.5)	PG 7	.49 (12.5)	1.02(26)	.20 (5)	.55 (14)
CD09AA-MZ	.16 - .31 (4 - 8)	PG 9	.60 (15.2)	1.10(28)	.24 (6)	.67 (17)
CD09NA-MZ	.16 - .31 (4 - 8)	3/8" NPT	.68 (17.2)	1.10(28)	.59 (15)	.67(17) / .75(19)
CD16MA-MZ	.24 - .39 (6 - 10)	M16 x 1,5	.63 (16.0)	1.10(28)	.24 (6)	.79 (20)
CD16MR-MZ	.24 - .31 (6 - 8)			1.18(30)		.75 (19)
CD11AA-MZ	.24 - .39 (6 - 10)	PG 11	.73 (18.5)	1.18(30)	.24 (6)	.79 (20)
CD20MA-MZ	.39 - .55 (10 - 14)	M20 x 1,5	.79 (20.0)	1.30(33)	.24 (6)	.94 (24)
CD20MR-MZ	.39 - .47 (10 - 12)					.87 (22)
CD13AA-MZ	.27 - .47 (7 - 12)	PG 13	.80 (20.3)	1.30(33)	.25(6.5)	.87 (22)
CD13NA-MZ	.27 - .47 (7 - 12)	1/2" NPT	.83 (21.1)	1.30(33)	.51 (13)	.87(22) / .94(24)
CD16AA-MZ	.39 - .55 (10 - 14)	PG 16	.88 (22.3)	1.30(33)	.25(6.5)	.94 (24)
CD25MA-MZ	.51 - .71 (13 - 18)	M25 x 1,5	.99 (25.0)	1.46 (37)	.27 (7)	1.18 (30)
CD21AA-MZ	.51 - .71 (13 - 18)	PG 21	1.12 (28.4)	1.46(37)	.27 (7)	1.18 (30)
CD21NA-MZ	.51 - .71 (13 - 18)	3/4" NPT	1.05 (26.7)	1.46(37)	.51 (13)	1.18 (30)
CD32MA-MZ	.71 - .98 (18 - 25)	M32 x 1,5	1.26 (32.0)	1.69(43)	.31 (8)	1.57 (40)
CD29NA-MZ	.71 - .98 (18 - 25)	1" NPT	1.35 (34.3)	1.69(43)	.75 (19)	1.57 (40)
CD40MA-MZ	.86 - 1.26 (22 - 32)	M40 x 1,5	1.58 (40.0)	1.97(50)	.31 (8)	1.97 (50)
CD50MA-MZ	1.26 - 1.50 (32 - 38)	M50 x 1,5	1.97 (50.0)	2.01(51)	.35 (9)	2.24 (57)
CD50MR-MZ	.98 - 1.22 (25 - 31)					2.24 (57)
CD63MA-MZ	1.46 - 1.73 (37 - 44)	M63 x 1,5	2.48 (63.0)	2.05(52)	.39 (10)	2.52(64) / 2.58(68)
CD63MR-MZ	1.14 - 1.38 (29 - 35)					2.52(64) / 2.68(68)

SPECIFICATIONS:

Pressure rating:
150 PSIG (10 BAR) NEMA 4x and 6
(Submersible) IP68

Materials:

Body & Clamping Nut: Nickel Plated Brass
Splined Bushing: Nylon 6/6
Form Seal: Buna-N
O-Ring(Optional): Buna-N

Operating Temperature:

-40°F to 212°F (-40°C to 100°C)

Also available in ATEX & EEx e versions!

